



Installation instructions

Akrapovič Exhaust System:

Slip-On

for the

Porsche Cayenne Turbo (type 958)

Porsche Cayenne Turbo S (type 958)

Porsche Cayenne S (type 958)

Porsche Cayenne Diesel (type 958)

Porsche Cayenne (type 958)

Porsche Cayenne Hybrid (type 958)



Installation instructions

Akrapovič Exhaust System:

Slip-On

for the

Porsche Cayenne Turbo (type 958)

Porsche Cayenne Turbo S (type 958)

Porsche Cayenne S (type 958)

Porsche Cayenne Diesel (type 958)

Porsche Cayenne (type 958)

Porsche Cayenne Hybrid (type 958)

Congratulations on purchasing an Akrapovič exhaust system. Please read the entire installation manual prior to undertaking any activities related to installation of your new Akrapovič exhaust system. In case you do not fully understand the manual or any of its parts, please contact your authorized dealer!

This product should be installed by someone with sufficient knowledge of exhaust systems and their installation, and appropriate hand or power tools. If you are not qualified for this work, please utilize a certified mechanic for installation. By installing Your Akrapovič exhaust system, you indicate that you have read the installation manual in its entirety and you agree with the terms stated herein.

It is your responsibility to follow all installation instruction guidelines supplied with the Akrapovič exhaust system and undertake all necessary safety precautions. Akrapovič d.d. assumes no responsibility for damages occurring from misuse, abuse, improper installation, improper operation, lack of responsible care, or all previously stated reasons resulting from incompatibility with other manufacturer's products and/or systems.

IMPORTANT INFORMATION

Exclusion of Certain Liability

1. The manufacturer, importer or dealer shall not be liable for any incidental damage including personal injury or any other damages caused by improper installation or operation of the Akrapovič exhaust system. When installing the Akrapovič exhaust system be careful that the exhaust system does not touch other parts sensitive to high temperature.
2. Akrapovič makes no representation or warranties with regard to damage caused by the improper installation, use and maintenance of the Akrapovič exhaust system. The warranty is limited to defects recognized by our technical department and due to normal use, and excludes items subject to normal wear (gaskets and damping wool). The guarantee is void in case of accident, modification, improper or competition use.
3. Do not attempt to install the Akrapovič exhaust system on a vehicle model for which it was not made or tested by Akrapovič.
4. When the exhaust system gets very hot during operation, be careful not to burn yourself on the exhaust system or parts which are in direct contact with it, even when the engine is not running. Also protect other people, especially children, from the injuries mentioned above.

1. In some cases Akrapovič exhaust system kits contain chemical products (ceramic anti-seizing grease; bolt sealant). Handle with care, do not inhale or swallow. Avoid excessive contact with skin, eyes or mucous membranes. Keep out of reach of children.
2. Technical specifications of Akrapovič exhaust systems and related products are subject to change without notice.
3. Before removing the original exhaust system from your vehicle, please compare the parts you received with the list of materials provided in the installation manual in order to assure that you have all the parts necessary for the installation of your new Akrapovič exhaust system.
4. Although this manual consists of instructions for installation in written form, as well as photographs and pictures representing individual steps of the installation, please note that the photographs and pictures are symbolic and are intended for representation of general overview only. The photographs and pictures contained herein should serve as a guideline only and actual installation of the exhaust system may not correspond with the photographs and pictures entirely.
5. The process of uninstalling the original exhaust system may vary depending on the existing exhaust system. Please follow the original exhaust system manufacturer's instructions for uninstalling the original exhaust system.

Trademarks

The Akrapovič Exhaust System Technology logo is a registered trademark of Akrapovič d.d.

Akrapovič website

Information about Akrapovič exhaust systems and related products is available on the Akrapovič website at:

<http://www.akrapovic.com/>

Copyright

No part of the Akrapovič exhaust system or its documentation may be reproduced or distributed in any form or by any means without the prior written authorization of the Akrapovič company.

© Akrapovič, d.d. All rights reserved.

Symbols

The following symbols are used throughout these installation instructions:



TOOLS REQUIRED



TIGHTENING TORQUE



INSTALLATION TIP



CAUTION OR WARNING



USE BOLT SEALANT; Apply 3 to 4 small drops of bolt sealant onto the cleaned and degreased threads before tightening the bolts. **WARNING! Avoid contact with skin, eyes and mucous membranes. Do not inhale fumes. Keep out of the reach of children.**



USE ANTI-SEIZE LEAD-FREE COPPER PASTE (black tube); Provides trouble-free and long-lasting protection against seizing, corrosion and rusting of bolts, threaded ends, nuts, joints, etc. Also protects against vibration, wear and impact. **WARNING! Avoid eye contact. Avoid excessive skin contact. Keep out of reach of children.**



USE ANTI-SEIZING GREASE (white tube); Prevents seizing, corrosion and excessive wear between the titanium components of your exhaust system. **WARNING! Avoid eye contact. Avoid excessive skin contact. Keep out of reach of children.**



Pipe cutting tool
T-handle swivelling 13 mm wrench
Bi-hex 15 mm socket
Pry bar



BEFORE INSTALLING, CHECK SCHEMATIC OF THE EXHAUST SYSTEM! THE LATEST VERSION OF THE PARTS LIST AND SCHEMATIC DRAWINGS OF THE PRODUCTS ARE AVAILABLE ON OUR WEB PAGE.



IF ANY ITEMS IN THE AKRAPOVIČ EXHAUST SYSTEM PACKAGE ARE MISSING, PLEASE CONTACT YOUR AUTHORIZED DEALER. KEEP THE SCHEMATIC FOR FUTURE REFERENCE.



THESE INSTALLATION INSTRUCTIONS MUST BE READ CAREFULLY IN ORDER TO ENSURE PROPER INSTALLATION AND OPERATION OF THE AKRAPOVIČ EXHAUST SYSTEM.



THE EXHAUST SYSTEM CAN BE EXTREMELY HOT. ALLOW THE EXHAUST AND ENGINE TO COOL DOWN BEFORE BEGINNING INSTALLATION.



WE ADVISE YOU TO LEAVE INSTALLATION TO A QUALIFIED SERVICEMAN. IMPROPER INSTALLATION MAY RESULT IN A SHORTER LIFETIME OF THE EXHAUST SYSTEM AND/OR DAMAGE TO THE VEHICLE.



THIS MANUAL IS SPECIFIC TO THE PORSCHE CAYENNE TURBO AND DIESEL. THERE MAY BE SOME DIFFERENCES IN INSTALLATION PROCEDURES FOR OTHER MODELS.

REMOVAL OF STOCK EXHAUST SYSTEM:

Put the vehicle onto a car lift.

- ! **WARNING: ensure that the car is lifted safely and properly in order to avoid the risk of vehicle damage, injury, or even death!**
- 1. **For Turbo, Turbo S, S, V6 and Hybrid models only:** mark the stock muffler's inlet pipes exactly at the impressed dots. Carefully cut the pipes, using pipe cutting tool or equivalent (**Figure 1**).
- ! **WARNING: make sure, not to damage any part of the vehicle during this procedure!**

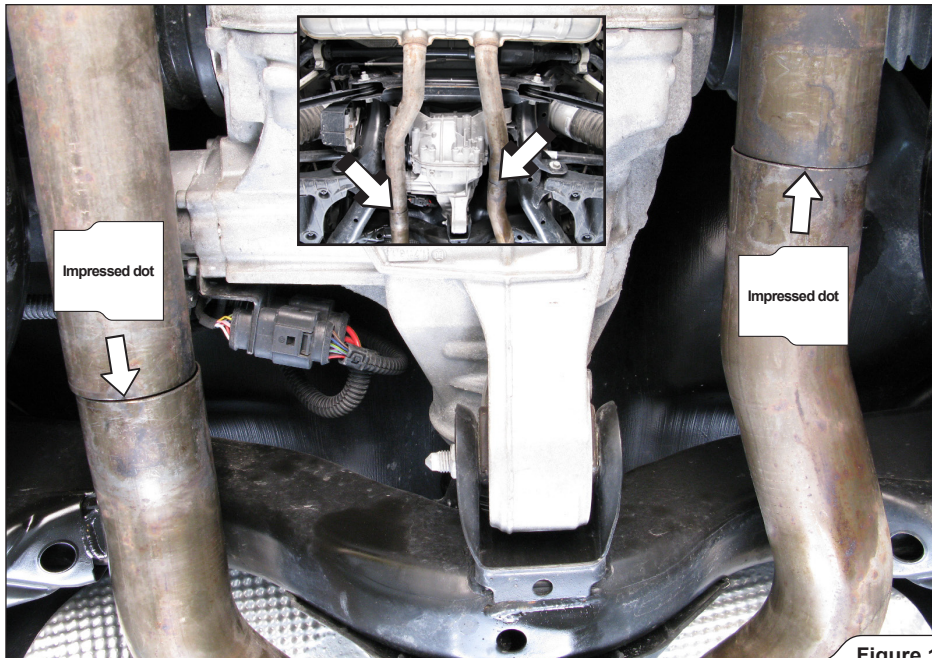

Figure 1

2. **For Diesel model only:** mark the stock muffler's inlet pipe **45mm** from the impressed dot (towards the back of the vehicle). Carefully cut the pipes, using pipe cutting tool or equivalent (Figure 2).

! **WARNING:** make sure, not to damage any part of the vehicle during this procedure!

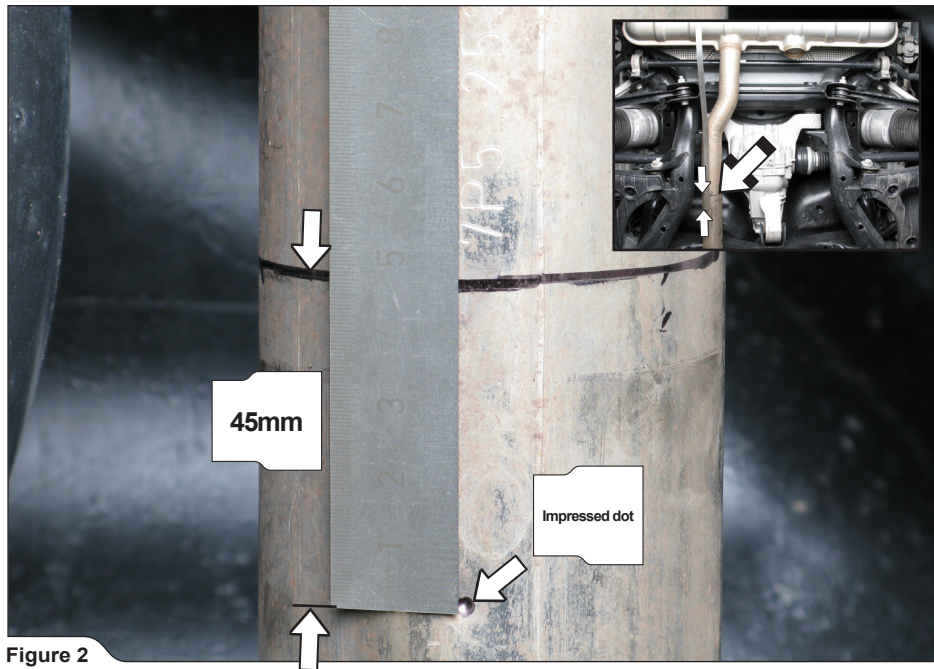

Figure 2

3. **For all models:** support the muffler, unscrew the marked bracket bolts on both sides and carefully remove the muffler off the vehicle (**Figure 3**).

! **WARNING:** make sure not to injure yourself, or damage any part of the vehicle during this procedure!

! **WARNING:** support the muffler during this procedure or you could injure yourself or damage the vehicle!

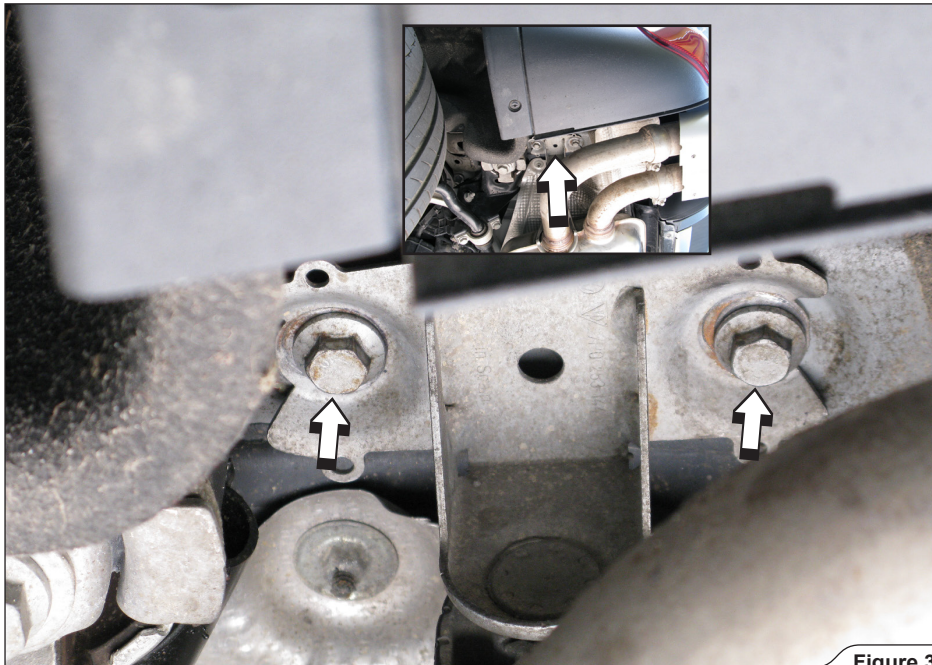

Figure 3

4. For all models: carefully remove the rubber brackets off the muffler (Figure 4).

✂ INSTALLATION TIP: for easier dismantling, lubricate the original rubber brackets (WD40).



Figure 4

INSTALLATION OF THE AKRAPOVIČ EXHAUST SYSTEM:

1. **For all models:** correctly assemble all the clamps, muffler's outlet pipes and stock rubber brackets onto the muffler; tighten the marked clamps and bolts on both sides of the muffler (**Figure 5, 6, 7**).

! **WARNING:** use anti-seize copper paste on all clamps' bolt and nut threads!

! **CAUTION:** in case you choose to grind off the spot welds and brake the outlet pipe's seals off, the Akrapovič exhaust system EC type approval is not valid!



Figure 5

- ! **WARNING:** adjust the outlet pipes, before tightening all the clamps and bolts (Figure 6)!
- ✂ **INSTALLATION TIP:** for easier mounting, lubricate the original rubber brackets (WD40).

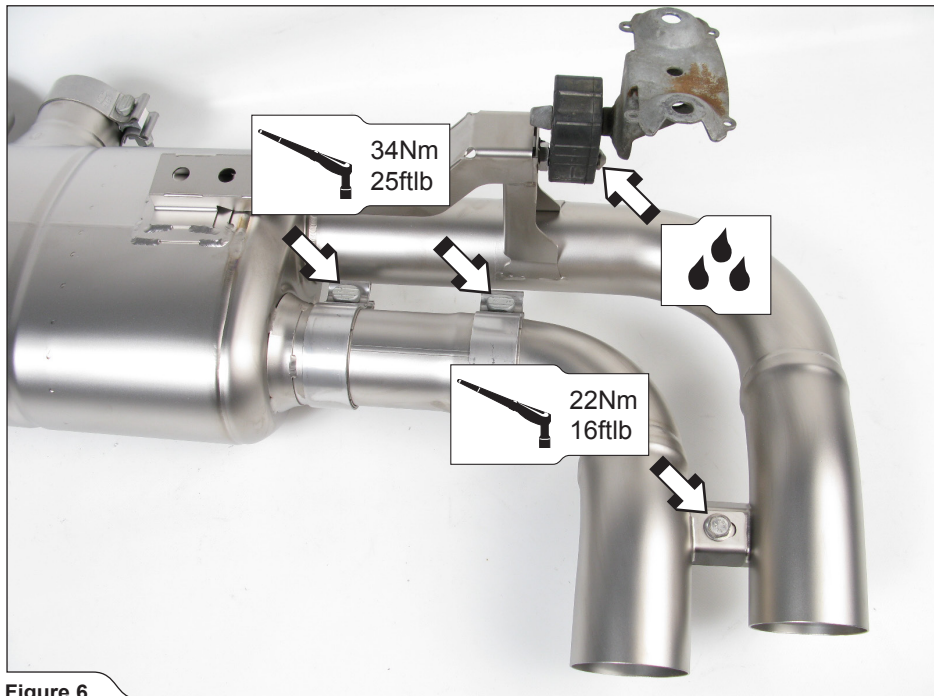

Figure 6

! WARNING: only hand tighten the clamps (Figure 7)!

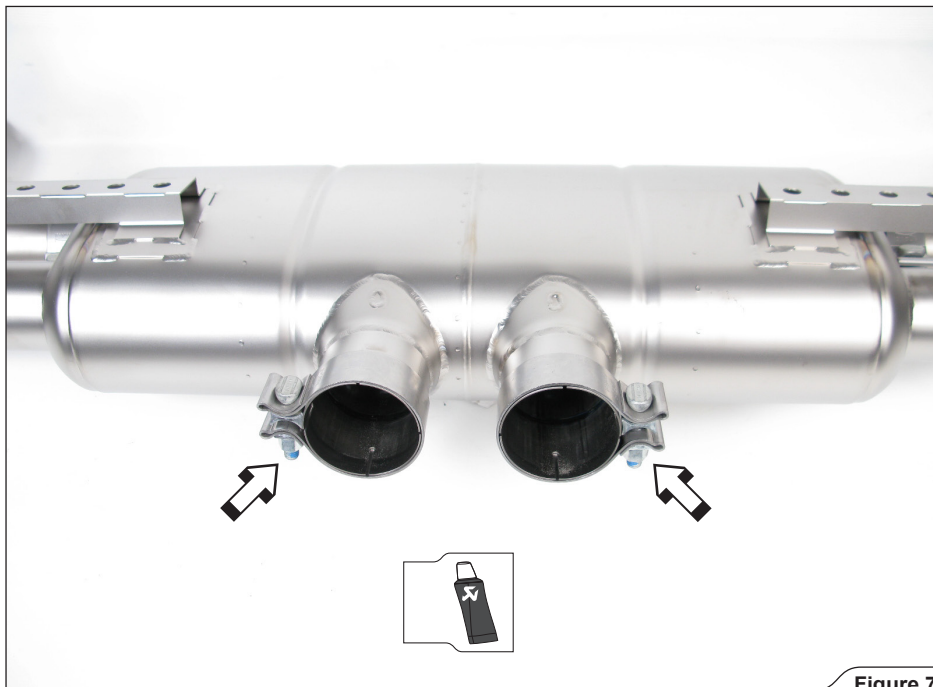

Figure 7

2. **For Turbo, Turbo S, S, V6 and Hybrid models only:** correctly assemble the adapters and clamps onto the muffler link pipes (**Figure 8, 9**).
- ! **CAUTION:** the adapters are not symmetrical; align the flat part of the adapters with upper plane of the link pipes (**Figure 9**)!
- ! **WARNING:** only hand tighten all the clamps!

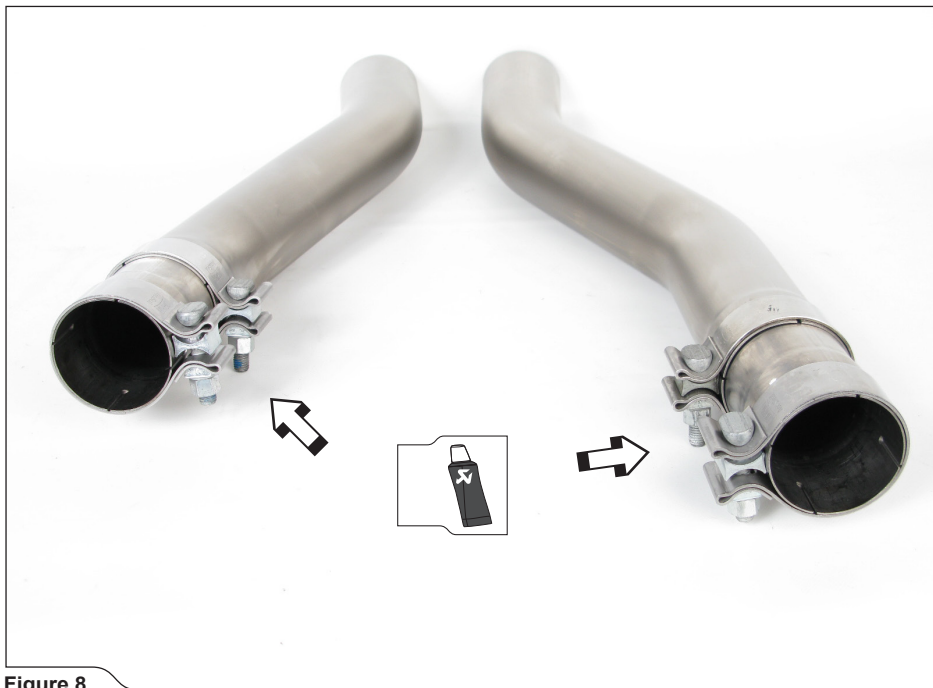

Figure 8

! **WARNING:** only hand tighten the clamps (Figure 9)!

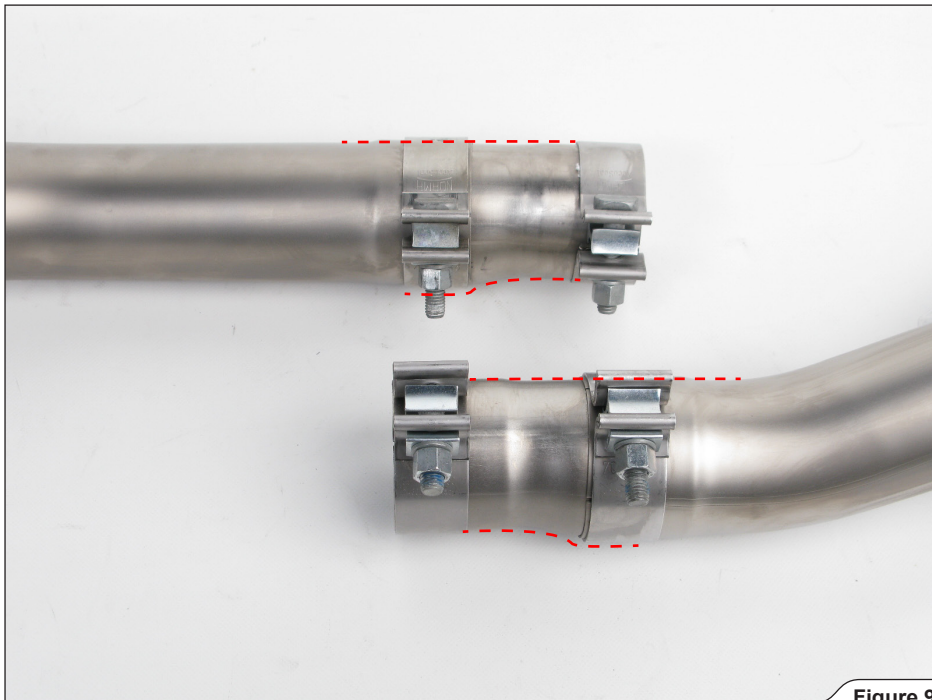

Figure 9

3. **For Diesel model only:** correctly assemble the Adapter and clamps onto the muffler link pipe (Figure 10, 11).

! **CAUTION:** the adapter is not simetrical; align the flat part of the adapter with upper plane of the link pipe (Figure 10)!

! **WARNING:** use anti-seize copper paste on all clamps' bolt and nut threads!



Figure 10

! **WARNING:** only hand tighten the clamps (Figure 11)!



Figure 11

4. **For Turbo, Turbo S, S, V6 and Hybrid models only:** slide the muffler link pipes all the way onto the stock middle pipes (**Figure 12**).

! **WARNING:** do not fully tighten the clamps yet!

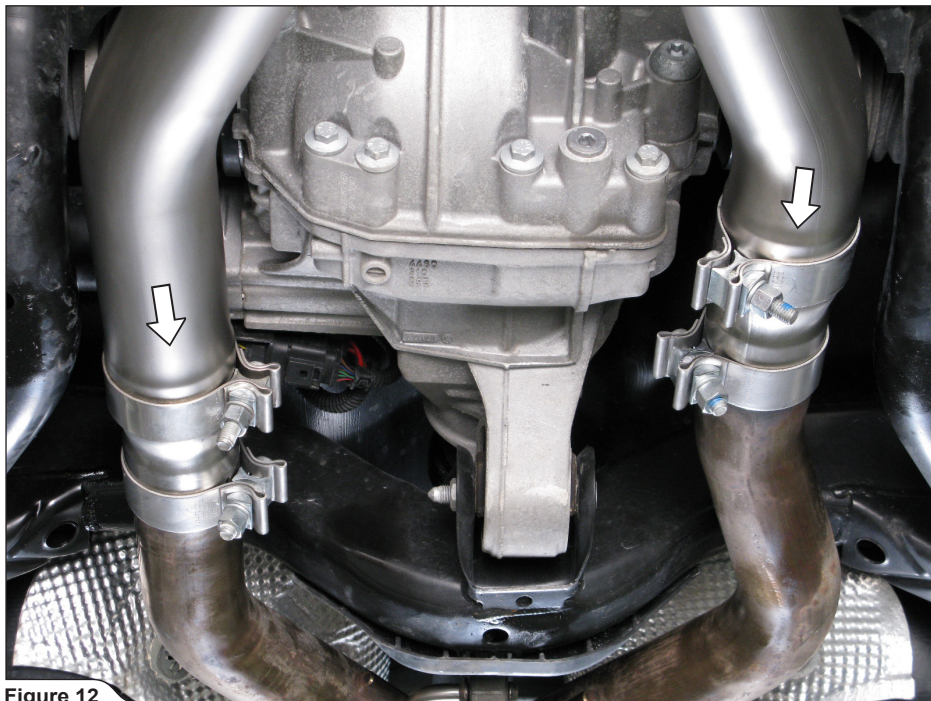

Figure 12

5. **For Diesel model only:** slide the muffler link pipe all the way onto the stock middle pipe (Figure 13).

! **WARNING:** do not fully tighten the clamps yet!

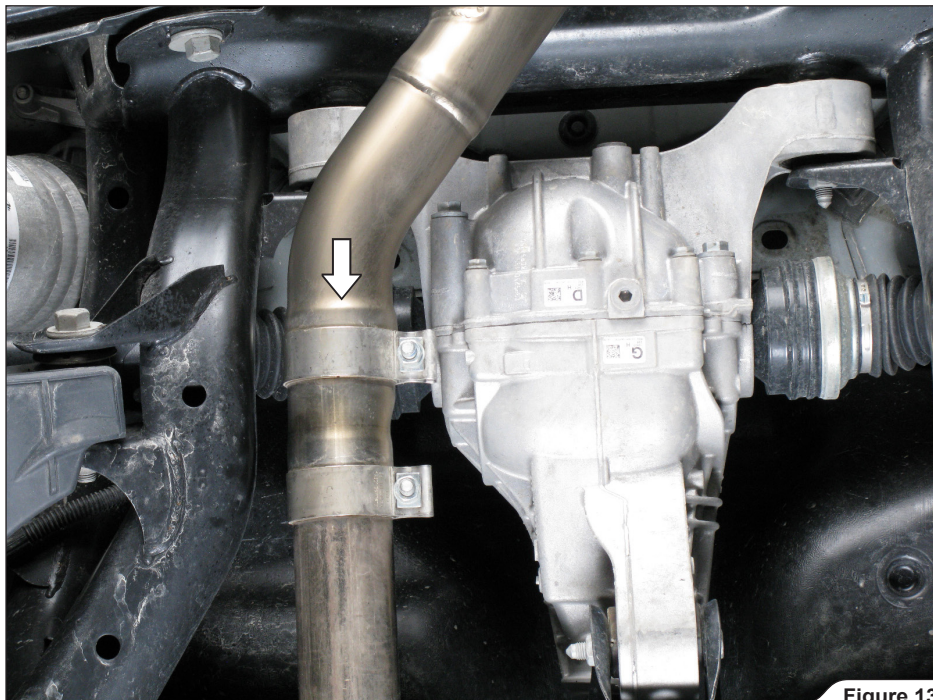

Figure 13

6. For Turbo, Turbo S, S, V6 and Hybrid models only: slide the muffler onto the link pipes (Figure 14).

!

WARNING: do not fully tighten the clamps yet!

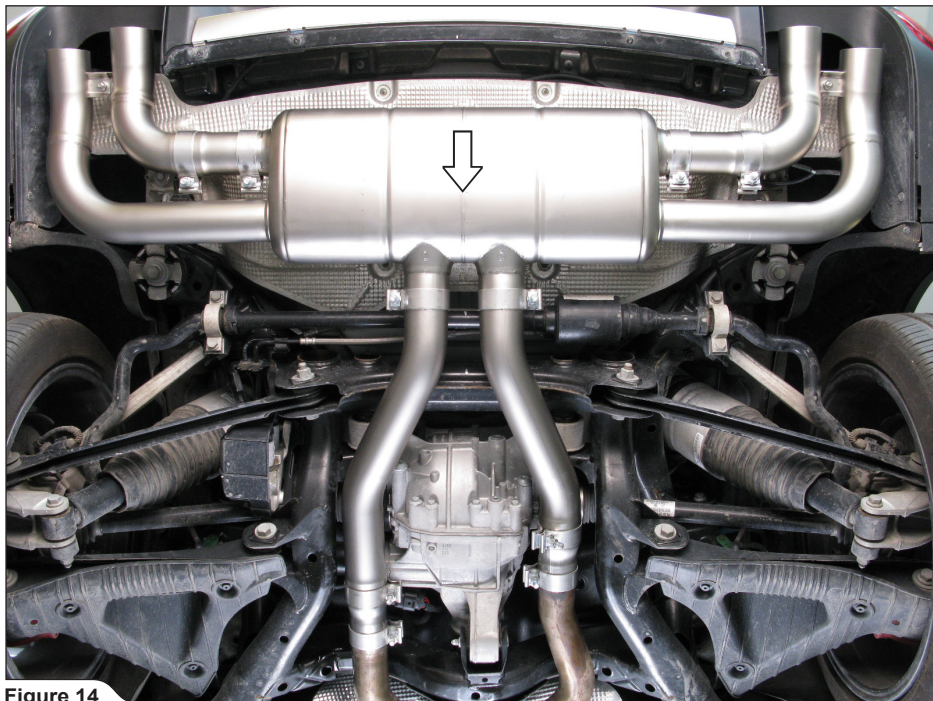

Figure 14

7. **For Diesel model only:** slide the muffler onto the link pipe (**Figure 15**).
! **WARNING:** do not fully tighten the clamps yet!

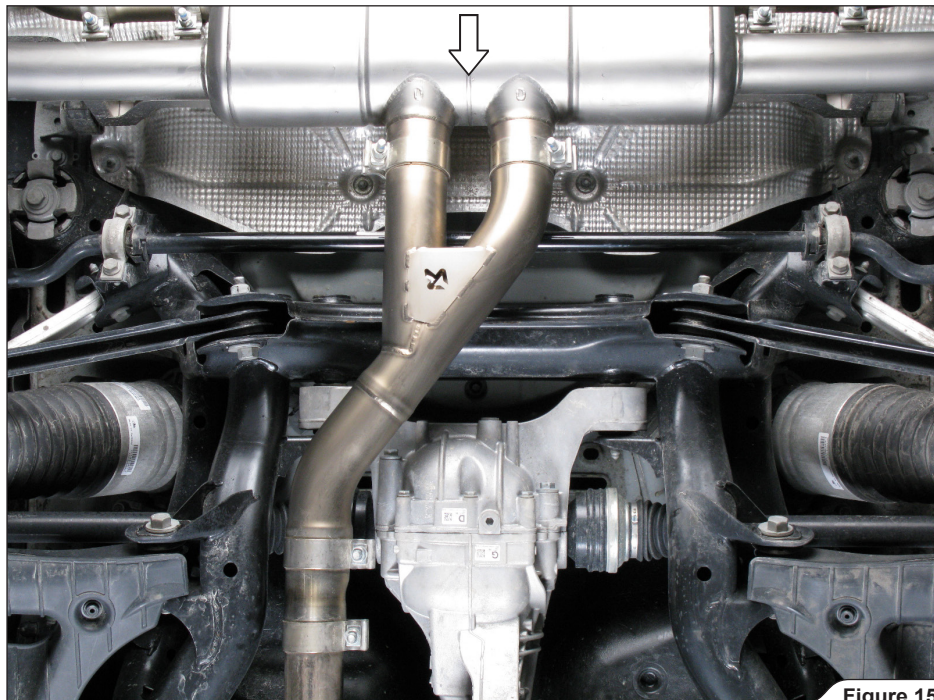

Figure 15

8. **For all models:** tighten the stock muffler rubber brackets onto the chassis (using stock bolts) on both sides of the vehicle (**Figure 16**).

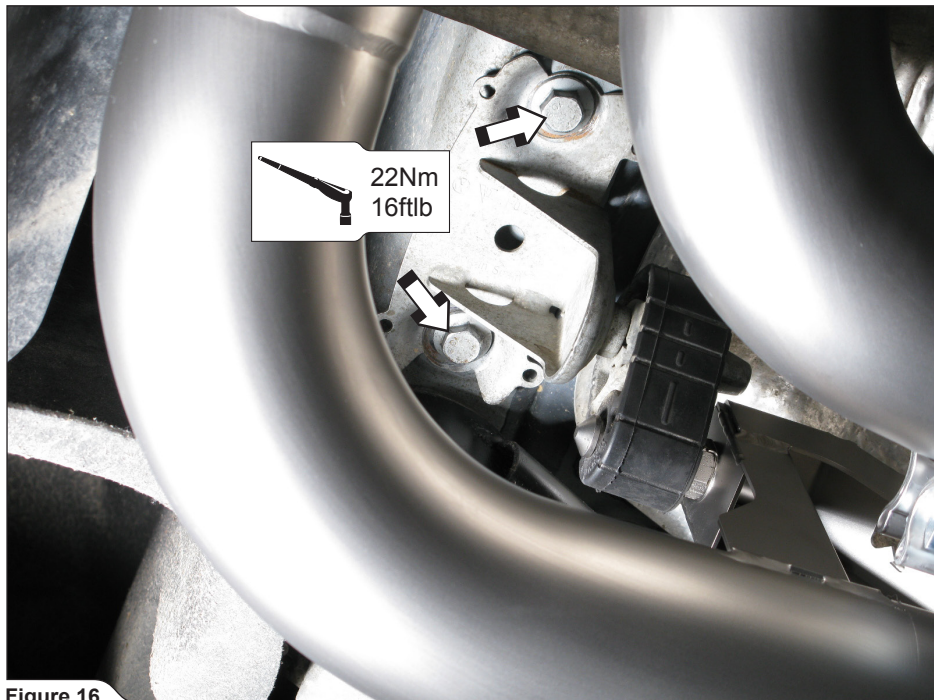
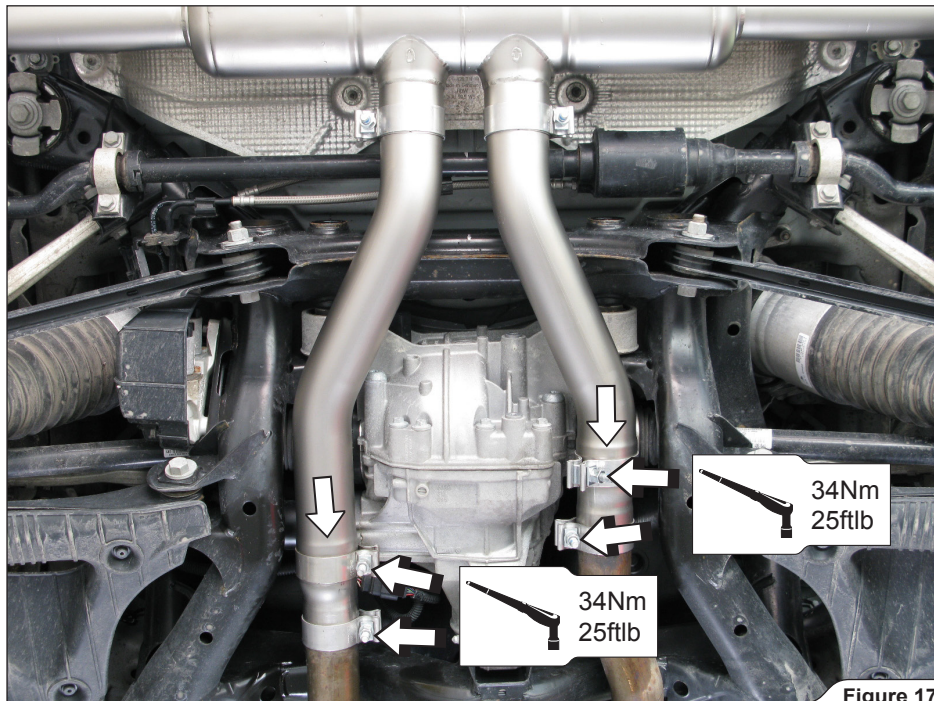

Figure 16

9. **For Turbo, Turbo S, S, V6 and Hybrid models only:** rotate the adapters till optimum position of muffler and link pipes (in respect to the chassis), than push the muffler link pipes all the way onto stock middle pipes and tighten the marked clamps to the specified torque (**Figure 17**).



10. **For Diesel model only:** rotate the adapter till optimum position of muffler and link pipe (in respect to the chassis), then push the muffler link pipe all the way onto stock middle pipe and tighten the marked clamps to the specified torque (**Figure 18**).

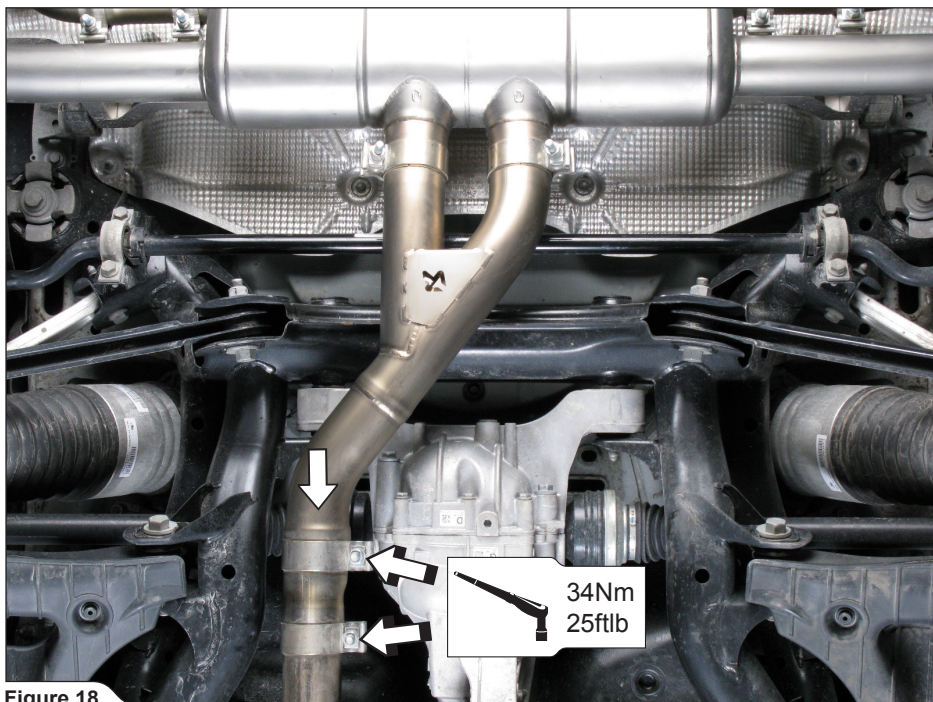

Figure 18

11. **For all models:** adjust the muffler lengthwise in such a way, that the rubber brackets are set vertically in respect to the vehicle chassis, than tighten the muffler's inlet clamps (**Figure 19, 20**).

! **WARNING:** make sure, not to injure yourself or damage any part of the vehicle during this procedure!

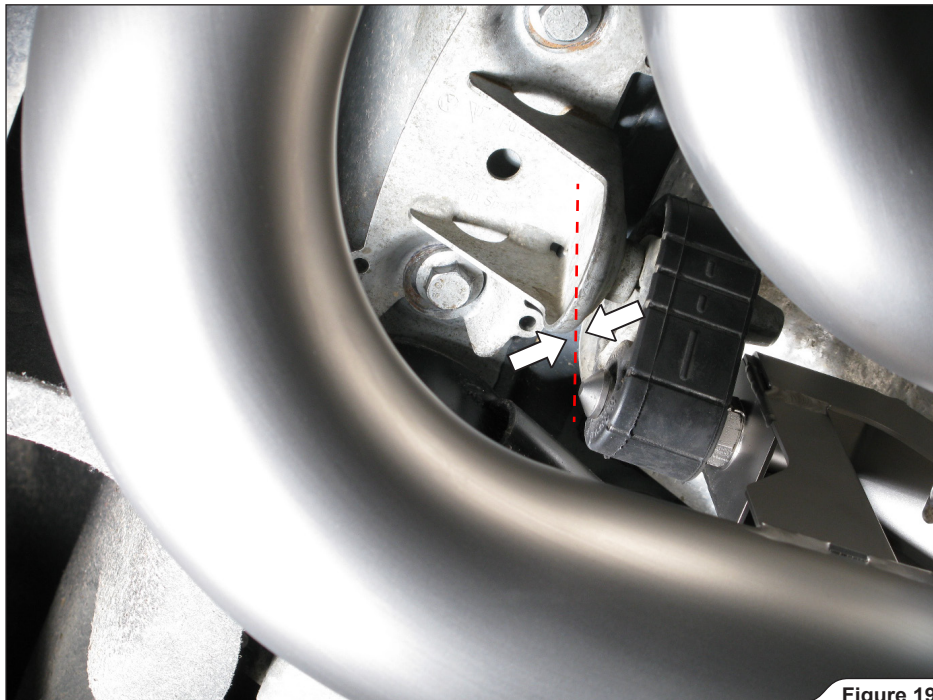

Figure 19

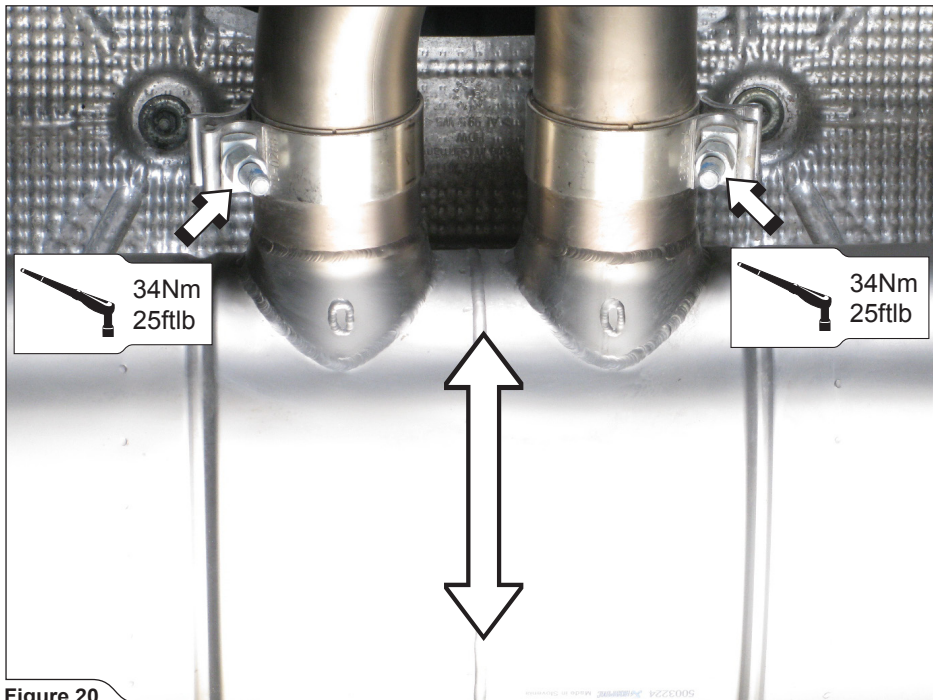

Figure 20

12. **For all models:** assemble the clamps and spherical rings onto the tail pipes, as shown (Figure 21).

! WARNING: use anti-seize copper paste on all clamp bolt threads!



Figure 21

13. **For all models:** slide the tail-pipes onto the muffler outlets. Rotate and center them in respect to rear bumper and according to your personal taste (**Figure 22, 23**).

! **WARNING:** make sure, not to damage tail pipes, bumper or any part of the vehicle during this procedure!



Figure 22



Figure 23

14. **For all models:** tighten tail pipe clamps to the specified torque on both sides of the vehicle (Figure 24).

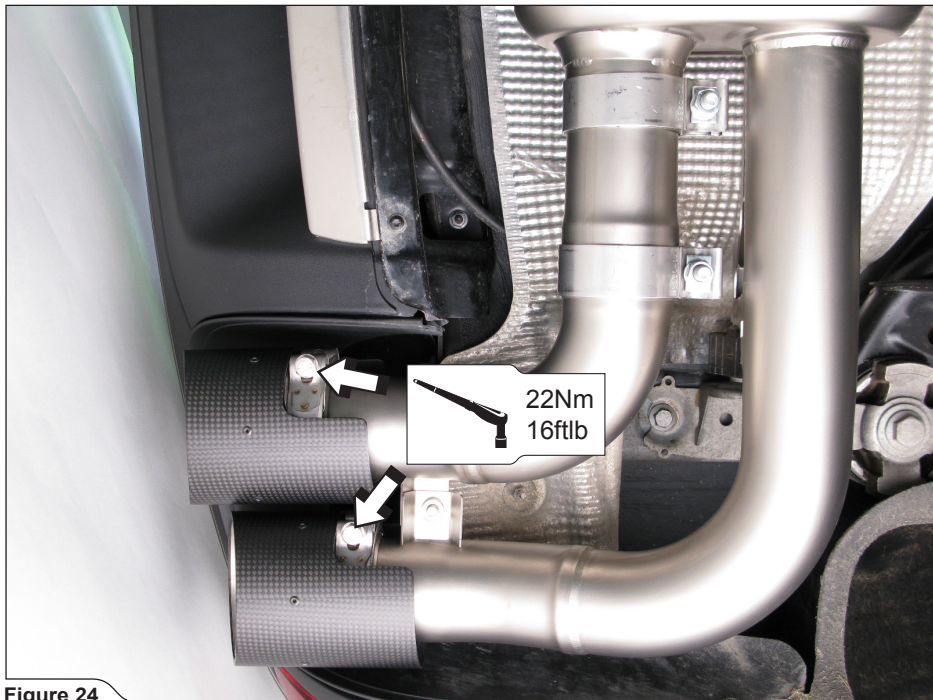

Figure 24

Final installation:

- ! **WARNING: check vehicle manufacturer manual for tightening torques (for dismantled stock parts)!**
- ! **WARNING: make sure all the nuts and bolts are sufficiently tightened. In case the exhaust system touches the cowling or other parts, repeat the adjustment of the exhaust system or contact your authorized dealer.**

MAINTENANCE OF THE AKRAPOVIČ EXHAUST SYSTEM:

1. Clean the titanium exhaust components with a multi-purpose spray lubricant (WD-40 or equivalent), carbon fiber exhaust components with soft and dry cloth and stainless steel components with soft cloth sprayed with contact cleaner, then wipe with soft and dry cloth. A change in the color of the exhaust system is normal due to high temperatures.
2. Periodically make sure all the bolts and springs are sufficiently tight.

- ! **WARNING: clean all exhaust components before the first start of the engine or the stains will burn onto the surfaces!**
- ! **IT IS NORMAL FOR WHITE SMOKE TO COME OUT OF THE MUFFLER AT FIRST OPERATION.**
- ! **DO NOT STAND BEHIND THE MUFFLER AT FIRST OPERATION.**
- ! **DO NOT USE AUTOMOTIVE WHEEL CLEANERS OR ANY CLEANING PRODUCTS WHICH CONTAIN ACIDIC ADDITIVES TO CLEAN THE AKRAPOVIČ EXHAUST SYSTEMS.**

WARNING

Please note that certain aftermarket exhaust systems may not comply with applicable California laws and regulations, and may therefore be prohibited for use on California highways or roads, or on roads or vehicles otherwise subject to emissions control requirements.

Akrapovič exhaust systems for automobiles and motorcycles mounted downstream of the catalytic converter (also known as “cat-back systems”) are considered “replacement parts” in California by the California Air Resources Board (CARB), and do not require an exemption or executive order from CARB to be sold in California. However, California prohibits the use of any aftermarket exhaust system that modifies, removes or replaces original equipment catalysts, unless CARB has issued an Executive Order as to such part or system.

Further, Akrapovič parts or exhaust systems used or intended for use on “racing vehicles” (i.e. a competition vehicle used exclusively for competition on closed-course circuits) do not require an exemption or Executive Order from CARB to be sold in California. However, such parts are prohibited from use on California public highways or roads, even if occasionally used “off-road.”

www.akrapovic.com

